

**Robert Bosch GmbH**  
Power Tools Division  
70745 Leinfelden-Echterdingen

[www.bosch-pt.com](http://www.bosch-pt.com)

2 609 140 533 (2007.12) O / 211 UNI

## GSB 13 RE Professional



<b>de</b> Originalbetriebsanleitung	<b>el</b> Πρωτότυπο οδηγιών χρήσης	<b>ro</b> Instrucțiuni de folosire originale
<b>en</b> Original instructions	<b>tr</b> Orijinal işletme talimatı	<b>bg</b> Оригинално ръководство за експлоатация
<b>fr</b> Notice originale	<b>pl</b> Instrukcja oryginalna	<b>sr</b> Originalno uputstvo za rad
<b>es</b> Manual original	<b>cs</b> Původním návodem k používání	<b>sl</b> Izvirna navodila
<b>pt</b> Manual original	<b>sk</b> Pôvodný návod na použitie	<b>hr</b> Originalne upute za rad
<b>it</b> Istruzioni originali	<b>hu</b> Eredeti használati utasítás	<b>et</b> Algupärane kasutusjuhend
<b>nl</b> Oorspronkelijke gebruiksaanwijzing	<b>ru</b> Руководство по эксплуатации	<b>lv</b> Oriģinālā lietošanas pamācība
<b>da</b> Original brugsanvisning	<b>uk</b> Оригінальна інструкція з експлуатації	<b>lt</b> Originali instrukcija
<b>sv</b> Bruksanvisning i original		
<b>no</b> Original driftsinstruks		
<b>fi</b> Alkuperäiset ohjeet		



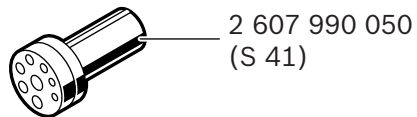
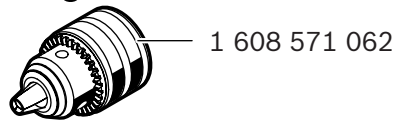
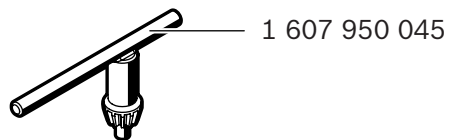
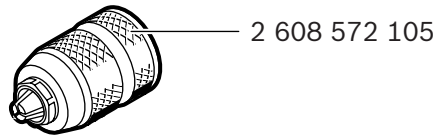
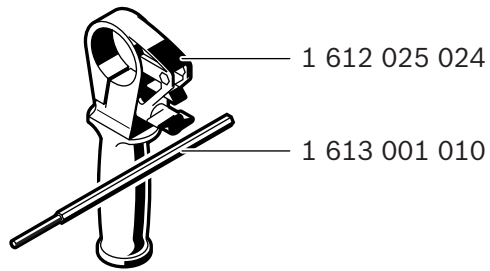

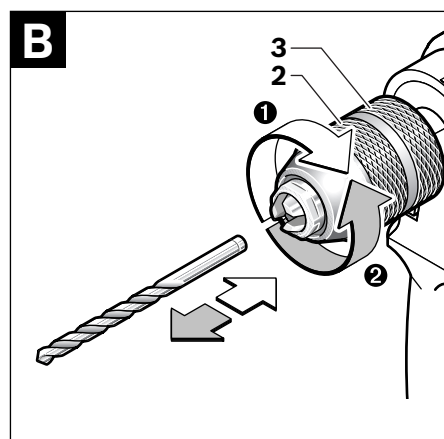
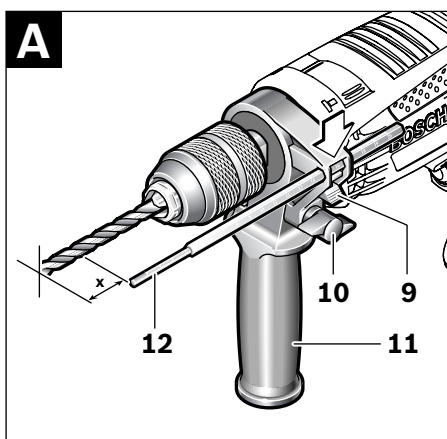
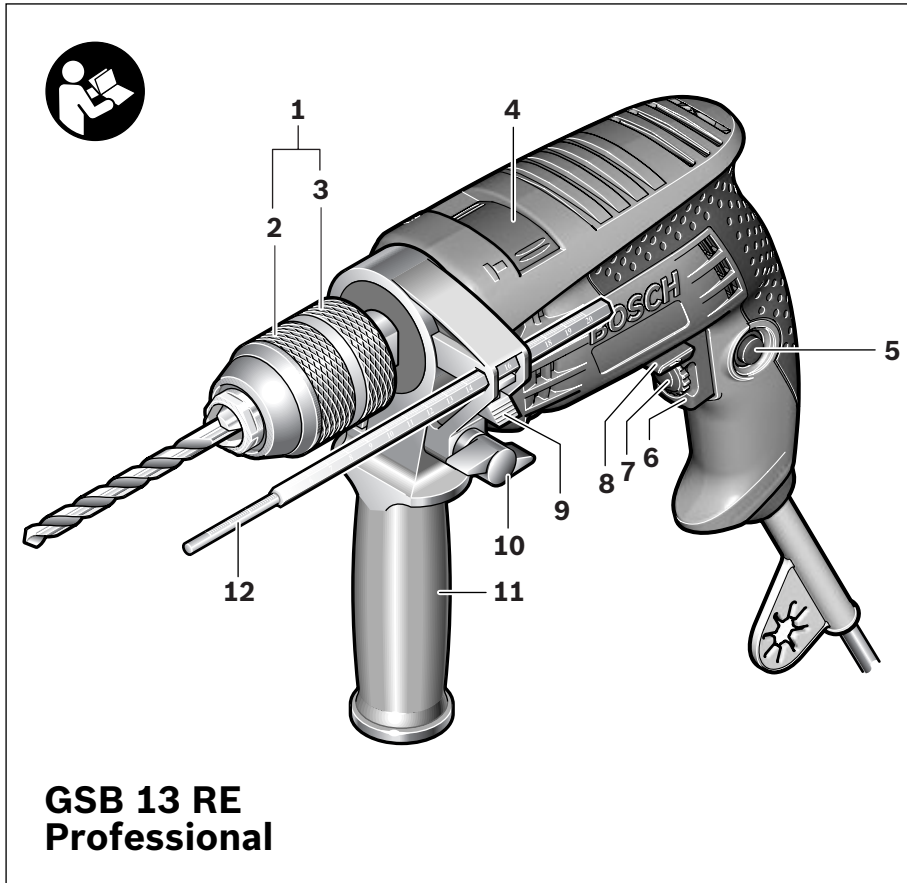

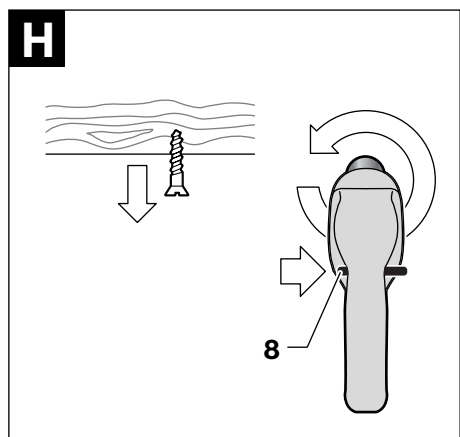
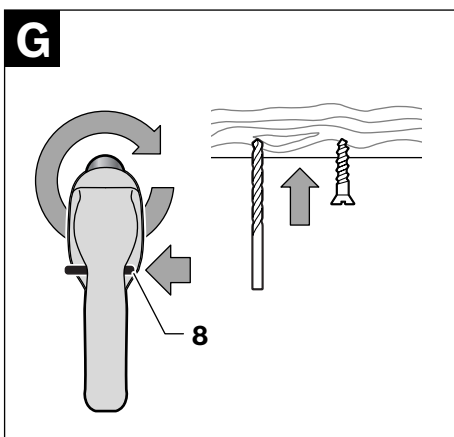
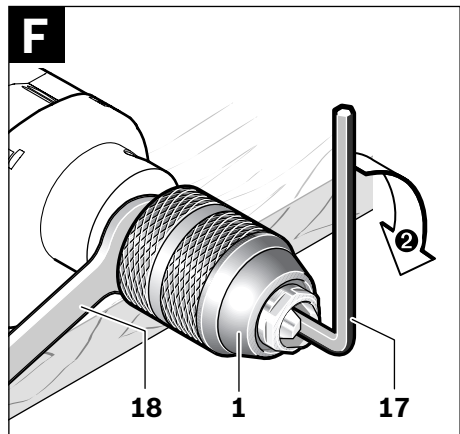
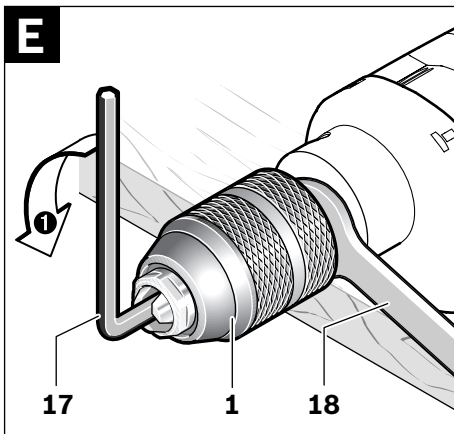
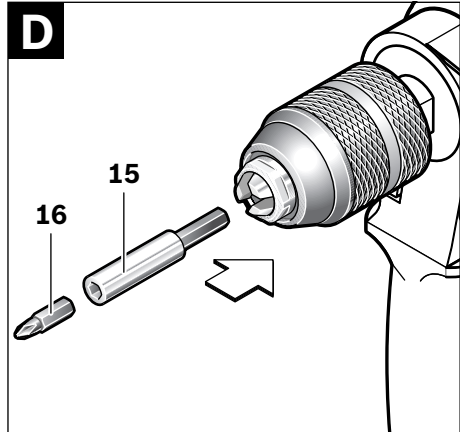
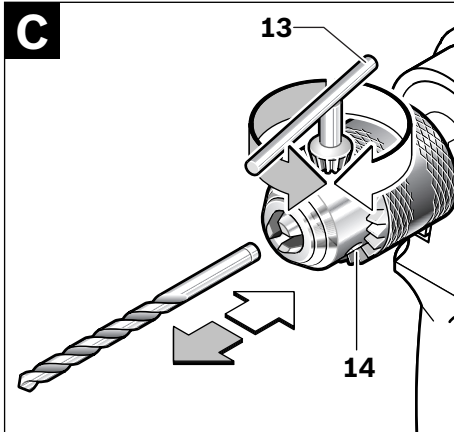

## General Power Tool Safety Warnings

**⚠ WARNING** Read all safety warnings and all instructions. Failure to follow the warnings and instructions may result in electric shock, fire and/or serious injury.

**Save all warnings and instructions for future reference.**

The term “power tool” in the warnings refers to your mains-operated (corded) power tool or battery-operated (cordless) power tool.

### 1) Work area safety

- a) **Keep work area clean and well lit.** Cluttered or dark areas invite accidents.
- b) **Do not operate power tools in explosive atmospheres, such as in the presence of flammable liquids, gases or dust.** Power tools create sparks which may ignite the dust or fumes.
- c) **Keep children and bystanders away while operating a power tool.** Distractions can cause you to lose control.

### 2) Electrical safety

- a) **Power tool plugs must match the outlet. Never modify the plug in any way. Do not use any adapter plugs with earthed (grounded) power tools.** Unmodified plugs and matching outlets will reduce risk of electric shock.
- b) **Avoid body contact with earthed or grounded surfaces, such as pipes, radiators, ranges and refrigerators.** There is an increased risk of electric shock if your body is earthed or grounded.
- c) **Do not expose power tools to rain or wet conditions.** Water entering a power tool will increase the risk of electric shock.
- d) **Do not abuse the cord. Never use the cord for carrying, pulling or unplugging the power tool. Keep cord away from heat, oil, sharp edges and moving parts.** Damaged or entangled cords increase the risk of electric shock.

e) **When operating a power tool outdoors, use an extension cord suitable for outdoor use.** Use of a cord suitable for outdoor use reduces the risk of electric shock.

f) **If operating a power tool in a damp location is unavoidable, use a residual current device (RCD) protected supply.** Use of an RCD reduces the risk of electric shock.

### 3) Personal safety

- a) **Stay alert, watch what you are doing and use common sense when operating a power tool. Do not use a power tool while you are tired or under the influence of drugs, alcohol or medication.** A moment of inattention while operating power tools may result in serious personal injury.
- b) **Use personal protective equipment. Always wear eye protection.** Protective equipment such as dust mask, non-skid safety shoes, hard hat, or hearing protection used for appropriate conditions will reduce personal injuries.
- c) **Prevent unintentional starting. Ensure the switch is in the off-position before connecting to power source and/or battery pack, picking up or carrying the tool.** Carrying power tools with your finger on the switch or energising power tools that have the switch on invites accidents.
- d) **Remove any adjusting key or wrench before turning the power tool on.** A wrench or a key left attached to a rotating part of the power tool may result in personal injury.
- e) **Do not overreach. Keep proper footing and balance at all times.** This enables better control of the power tool in unexpected situations.
- f) **Dress properly. Do not wear loose clothing or jewellery. Keep your hair, clothing and gloves away from moving parts.** Loose clothes, jewellery or long hair can be caught in moving parts.

**g) If devices are provided for the connection of dust extraction and collection facilities, ensure these are connected and properly used.** Use of dust collection can reduce dust-related hazards.

#### 4) Power tool use and care

**a) Do not force the power tool. Use the correct power tool for your application.** The correct power tool will do the job better and safer at the rate for which it was designed.

**b) Do not use the power tool if the switch does not turn it on and off.** Any power tool that cannot be controlled with the switch is dangerous and must be repaired.

**c) Disconnect the plug from the power source and/or the battery pack from the power tool before making any adjustments, changing accessories, or storing power tools.** Such preventive safety measures reduce the risk of starting the power tool accidentally.

**d) Store idle power tools out of the reach of children and do not allow persons unfamiliar with the power tool or these instructions to operate the power tool.** Power tools are dangerous in the hands of untrained users.

**e) Maintain power tools. Check for misalignment or binding of moving parts, breakage of parts and any other condition that may affect the power tool's operation. If damaged, have the power tool repaired before use.** Many accidents are caused by poorly maintained power tools.

**f) Keep cutting tools sharp and clean.** Properly maintained cutting tools with sharp cutting edges are less likely to bind and are easier to control.

**g) Use the power tool, accessories and tool bits etc. in accordance with these instructions, taking into account the working conditions and the work to be performed.** Use of the power tool for operations different from those intended could result in a hazardous situation.

#### 5) Service

**a) Have your power tool serviced by a qualified repair person using only identical replacement parts.** This will ensure that the safety of the power tool is maintained.

## Machine-specific Safety Warnings

▶ **Wear hearing protection when using impact drills.** The influence of noise can lead to loss of hearing.

▶ **Always use the auxiliary handle supplied with the machine.** Loss of control can cause personal injury.

▶ **Use appropriate detectors to determine if utility lines are hidden in the work area or call the local utility company for assistance.** Contact with electric lines can lead to fire and electric shock. Damaging a gas line can lead to explosion. Penetrating a water line causes property damage or may cause an electric shock.

▶ **Switch off the power tool immediately when the tool insert jams. Be prepared for high reaction torque that can cause kick-back.** The tool insert jams when:  
– the power tool is subject to overload or  
– it becomes wedged in the workpiece.

▶ **Hold the power tool only by the insulated gripping surfaces when performing an operation where the cutting tool may contact hidden wiring or its own cord.** Contact with a “live” wire will also make exposed metal parts of the power tool “live” and shock the operator.

▶ **When working with the machine, always hold it firmly with both hands and provide for a secure stance.** The power tool is guided more secure with both hands.

▶ **Secure the workpiece.** A workpiece clamped with clamping devices or in a vice is held more secure than by hand.

▶ **Keep your workplace clean.** Blends of materials are particularly dangerous. Dust from light alloys can burn or explode.

## 16 | English

- ▶ **Always wait until the machine has come to a complete stop before placing it down.** The tool insert can jam and lead to loss of control over the power tool.
- ▶ **Never use the machine with a damaged cable. Do not touch the damaged cable and pull the mains plug when the cable is damaged while working.** Damaged cables increase the risk of an electric shock.

- 12 Depth stop\*
- 13 Chuck key\*
- 14 Key type drill chuck\*
- 15 Universal bit holder\*
- 16 Screwdriver bit\*
- 17 Allen Key\*\*
- 18 Open-end spanner\*\*

\*The accessories illustrated or described are not included as standard delivery.

\*\*Commercially available (not included in the delivery scope)

## Functional Description



**Read all safety warnings and all instructions.** Failure to follow the warnings and instructions may result in electric shock, fire and/or serious injury.

While reading the operating instructions, unfold the graphics page for the machine and leave it open.

### Intended Use

The machine is intended for impact drilling in brick, concrete and stone as well as for drilling in wood, metal and plastic. Machines with electronic control and right/left rotation are also suitable for screwdriving and thread-cutting.

### Product Features

The numbering of the product features refers to the illustration of the machine on the graphics page.

- 1 Keyless chuck\*
- 2 Front sleeve
- 3 Rear sleeve
- 4 "Drilling/Impact Drilling" selector switch
- 5 Lock-on button for On/Off switch
- 6 On/Off switch
- 7 Thumbwheel for speed preselection (not for machine version 3 601 B17 103)
- 8 Rotational direction switch
- 9 Button for depth stop adjustment
- 10 Wing bolt for adjustment of auxiliary handle
- 11 Auxiliary handle\*

### Technical Data

Impact Drill	GSB 13 RE Professional	
Article number		3 601 B17 1..
Rated power input	W	600
Output power	W	301
No-load speed	rpm	0 – 2800
Rated speed	rpm	1570
Impact rate	bpm	25070
Rated torque	Nm	1.8
Right/left rotation		●
Spindle collar dia.	mm	43
Max. drilling dia.		
– Brickwork	mm	15
– Concrete	mm	13
– Steel	mm	10
– Wood	mm	25
Chuck clamping range	mm	1.5 – 13
Weight according to EPTA-Procedure 01/2003	kg	1.8
Protection class		□/II

The values given are valid for nominal voltages [U] of 230/240 V. For lower voltage and models for specific countries, these values can vary.

Please observe the article number on the type plate of your machine. The trade names of the individual machines may vary.

### Noise/Vibration Information

Measured values determined according to EN 60745.

Typically the A-weighted noise levels of the product are: Sound pressure level 93 dB(A); Sound power level 104 dB(A). Uncertainty K=3 dB.

#### Wear hearing protection!

Vibration total values (triax vector sum) determined according to EN 60745:

Drilling into metal: Vibration emission value  $a_h = 3 \text{ m/s}^2$ , Uncertainty  $K=1.5 \text{ m/s}^2$ ,  
Impact drilling into concrete: Vibration emission value  $a_h = 26 \text{ m/s}^2$ , Uncertainty  $K=3 \text{ m/s}^2$ ,  
Screwdriving: Vibration emission value  $a_h < 2.5 \text{ m/s}^2$ , Uncertainty  $K=1.5 \text{ m/s}^2$ .

The vibration emission level given in this information sheet has been measured in accordance with a standardised test given in EN 60745 and may be used to compare one tool with another. It may be used for a preliminary assessment of exposure.

The declared vibration emission level represents the main applications of the tool. However if the tool is used for different applications, with different accessories or poorly maintained, the vibration emission may differ. This may significantly increase the exposure level over the total working period.

An estimation of the level of exposure to vibration should also take into account the times when the tool is switched off or when it is running but not actually doing the job. This may significantly reduce the exposure level over the total working period.

Identify additional safety measures to protect the operator from the effects of vibration such as: maintain the tool and the accessories, keep the hands warm, organisation of work patterns.

### Declaration of Conformity

We declare under our sole responsibility that the product described under "Technical Data" is in conformity with the following standards or standardization documents: EN 60745 according to the provisions of the directives 2004/108/EC, 98/37/EC (until Dec. 28, 2009), 2006/42/EC (from Dec. 29, 2009 on).

Technical file at:  
Robert Bosch GmbH, PT/ESC,  
D-70745 Leinfelden-Echterdingen

Dr. Egbert Schneider Senior Vice President Engineering	Dr. Eckerhard Strötgen Head of Product Certification
--	--

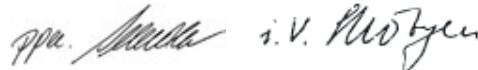

06.11.2007, Robert Bosch GmbH, Power Tools Division  
D-70745 Leinfelden-Echterdingen

### Assembly

- ▶ **Before any work on the machine itself, pull the mains plug.**

#### Auxiliary Handle (see figure A)

- ▶ **Operate your machine only with the auxiliary handle 11.**

The auxiliary handle **11** can be set to any position for a secure and low-fatigue working posture.

Turn the wing bolt for adjustment of the auxiliary handle **10** in anticlockwise direction and set the auxiliary handle **11** to the required position. Then tighten the wing bolt **10** again in clockwise direction.

#### Adjusting the Drilling Depth (see figure A)

The required drilling depth **X** can be set with the depth stop **12**.

Press the button for the depth stop adjustment **9** and insert the depth stop into the auxiliary handle **11**.

Pull out the depth stop until the distance between the tip of the drill bit and the tip of the depth stop correspond with the desired drilling depth **X**.



## Changing the Tool

### Keyless Chuck (see figure B)

Hold the rear sleeve **3** of the keyless chuck **1** tight and turn the front sleeve **2** in rotation direction **1**, until the tool can be inserted. Insert the tool.

Hold the rear sleeve **3** of the keyless chuck **1** tight and firmly turn the front sleeve **2** in rotation direction **2** by hand until the locking action is no longer heard. This automatically locks the drill chuck.

The locking is released again to remove the tool when the front sleeve **2** is turned in the opposite direction.

### Key Type Drill Chuck (see figure C)

- ▶ **Wear protective gloves when changing the tool.** The drill chuck can become very hot during longer work periods.

Open the key type drill chuck **14** by turning until the tool can be inserted. Insert the tool.

Insert the chuck key **13** into the corresponding holes of the key type drill chuck **14** and clamp the tool uniformly.

### Screwdriver Tools (see figure D)

When working with screwdriver bits **16**, a universal bit holder **15** should always be used. Use only screwdriver bits that fit the screw head.

For driving screws, always position the "Drilling/Impact Drilling" selector switch **4** to the "Drilling" symbol.

## Replacing the Drill Chuck

### Removing the Drill Chuck (see figure E)

To dismount the keyless chuck **1**, clamp an Allen key **17** into the keyless chuck **1** and position an open-end spanner **18** (size 14 mm mm) against the spanner flats of the drive spindle. Place the machine on a firm support, e.g., a workbench. Hold the open-end spanner **18** firmly and loosen the keyless chuck **1** by turning the Allen key **17**

in rotation direction **1**. Loosen a tight seated keyless chuck by giving the long end of the Allen key **17** a blow. Remove the Allen key from the keyless chuck and completely unscrew the keyless chuck.

The key type drill chuck **14** is removed in the same manner as the keyless chuck.

### Mounting the Drill Chuck (see figure F)

The keyless chuck/key type drill chuck is mounted in reverse order.

 **The drill chuck must be tightened with a tightening torque of approx. 30–35 Nm.**

## Dust/Chip Extraction

- ▶ Dusts from materials such as lead-containing coatings, some wood types, minerals and metal can be harmful to one's health. Touching or breathing-in the dusts can cause allergic reactions and/or lead to respiratory infections of the user or bystanders. Certain dusts, such as oak or beech dust, are considered as carcinogenic, especially in connection with wood-treatment additives (chromate, wood preservative). Materials containing asbestos may only be worked by specialists.
  - Use dust extraction whenever possible.
  - Provide for good ventilation of the working place.
  - It is recommended to wear a P2 filter-class respirator.

Observe the relevant regulations in your country for the materials to be worked.

## Operation

### Starting Operation

- ▶ **Observe correct mains voltage! The voltage of the power source must agree with the voltage specified on the nameplate of the machine. Power tools marked with 230 V can also be operated with 220 V.**

### Reversing the Rotational Direction (see figures G–H)

The rotational direction switch **8** is used to reverse the rotational direction of the machine. However, this is not possible with the On/Off switch **6** actuated.

**Right Rotation:** For drilling and driving in screws, push the rotational direction switch **8** left to the stop.

**Left Rotation:** For loosening and unscrewing screws and nuts, press the rotational direction switch **8** through to the right stop.

### Setting the Operating Mode



#### Drilling and Screwdriving

Set the selector switch **4** to the “Drilling” symbol.



#### Impact Drilling

Set the selector switch **4** to the “Impact drilling” symbol.

The selector switch **4** engages noticeably and can also be actuated with the machine running.

### Switching On and Off

To **start** the machine, press the On/Off switch **6** and keep it depressed.

To lock the **pressed** On/Off switch **6**, press the lock-on button **5**.

To **switch off** the machine, release the On/Off switch **6** or when it is locked with the lock-on button **5**, briefly press the On/Off switch **6** and then release it.

### Adjusting the Speed/Impact Frequency

The speed/impact rate of the switched on power tool can be variably adjusted, depending on how far the On/Off switch **6** is pressed.

Light pressure on the On/Off switch **6** results in low speed/impact rate. Further pressure on the switch increases the speed/impact rate.

### Preselecting the Speed/Impact Frequency (not for machine version 3 601 B17 103)

With the thumbwheel for speed preselection **7**, the required speed/impact frequency can be preselected even during operation.

The required speed/impact frequency depends on the material and the working conditions, and can be determined through practical testing.

### Working Advice

- ▶ **Apply the power tool to the screw/nut only when it is switched off.** Rotating tool inserts can slip off.

### Tips

After longer periods of working at low speed, allow the machine to cool down by running it for approx. 3 minutes at maximum speed with no load.

For drilling in tiles, set the selector switch **4** to the “Drilling” symbol. Do not switch over to the symbol “Impact Drilling” or work with impact until after drilling through the tile.

Use carbide tipped drill bits when working in concrete, masonry and brick wall.

For drilling in metal, use only perfectly sharpened HSS drill bits (HSS=high-speed steel). The appropriate quality is guaranteed by the Bosch accessories program.

Twist drills from 2.5–10 mm can easily be sharpened with the drill bit sharpener (see accessories).

## Maintenance and Service

### Maintenance and Cleaning

- ▶ **Before any work on the machine itself, pull the mains plug.**
- ▶ **For safe and proper working, always keep the machine and ventilation slots clean.**

If the machine should fail despite the care taken in manufacturing and testing procedures, repair should be carried out by an after-sales service centre for Bosch power tools.

In all correspondence and spare parts order, please always include the 10-digit article number given on the type plate of the machine.

**WARNING! Important instructions for connecting a new 3-pin plug to the 2-wire cable.**

The wires in the cable are coloured according to the following code:

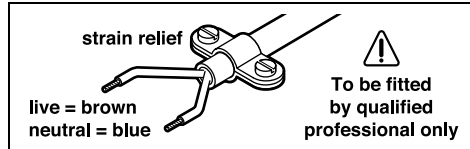

Do **not** connect the blue or brown wire to the earth terminal of the plug.

**Important:** If for any reason the moulded plug is removed from the cable of this power tool, it must be disposed of safely.

**After-sales service and customer assistance**

Our after-sales service responds to your questions concerning maintenance and repair of your product as well as spare parts. Exploded views and information on spare parts can also be found under:

**www.bosch-pt.com**

Our customer consultants answer your questions concerning best buy, application and adjustment of products and accessories.

**Great Britain**

Robert Bosch Ltd. (B.S.C.)  
P.O. Box 98  
Broadwater Park  
North Orbital Road  
Denham  
Uxbridge  
UB 9 5HJ  
Tel. Service: +44 (0844) 736 0109  
Fax: +44 (0844) 736 0146  
E-Mail: SPT-Technical.de@de.bosch.com

**Ireland**

Origo Ltd.  
Unit 23 Magna Drive  
Magna Business Park  
City West  
Dublin 24  
Tel. Service: +353 (01) 4 66 67 00  
Fax: +353 (01) 4 66 68 88

**Australia, New Zealand and Pacific Islands**

Robert Bosch Australia Pty. Ltd.  
Power Tools  
Locked Bag 66  
Clayton South VIC 3169  
Customer Contact Center  
Inside Australia:  
Phone: +61 (01300) 307 044  
Fax: + 61 (01300) 307 045  
Inside New Zealand:  
Phone: +64 (0800) 543 353  
Fax: +64 (0800) 428 570  
Outside AU and NZ:  
Phone: +61 (03) 9541 5555  
www.bosch.com.au

**Disposal**

The machine, accessories and packaging should be sorted for environmental-friendly recycling.

**Only for EC countries:**

Do not dispose of power tools into household waste!  
According to the European Guideline 2002/96/EC for Waste Electrical and Electronic Equipment and its implementation into national right, power tools that are no longer usable must be collected separately and disposed of in an environmentally correct manner.

**Subject to change without notice.**